

DECOILER

H1250/1500ZR/10M/U/AP

Decoiler for strip material

Machine consisting of:

Massive steel construction, designed to move machine by a fork lift

Base plate equipped with height adjustable feet

Machine equipped with pneumatic pressing arm

Mandrel 1500ZR

- Three-jaw mandrel, clamping diameter centrally adjustable by lever
- Process flow direction left – right
- Maximal coil outer- \varnothing 1450 mm
- Clamping- \varnothing of the mandrel 375 - 520 mm
- Maximum strip width 300 mm
- Maximal loading capacity 1250 kg
- Rotation speed 1 – 15 min⁻¹

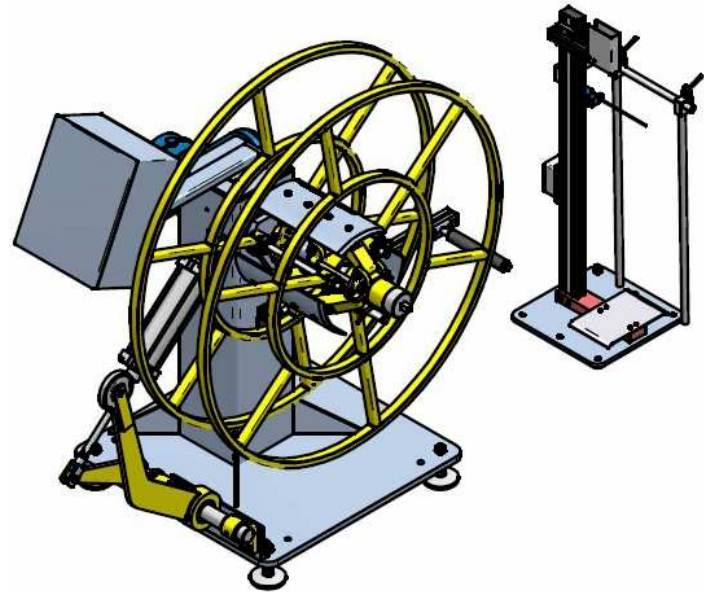

Drive system

- asynchronous motor, frequency converter
- Adjustable rotation speed
- Gear box with adjustable friction clutch

Loop control system U

- Loop control mounted on separate standing steel base plate, placed in the middle of the loop
- Ultrasonic sensor as well as a bar limit switch mounted at the top of the system, contact plate at the bottom onto the base plate
- Adjustable lateral guiding bars
- Continuous speed control by ultra sonic sensor
- Bar limit switch provides signal usable for the following machine in case of "Loop to short" situation

Control system

- Wiring accorded to EN-60204
- Electrical supply 400 V / 50 Hz
3L+N+PE
pre-fuse 10 A
- Painting structured light grey RAL 7035
rotating parts yellow, RAL 1003

